



Kompakt-Magnetriegel

neu!

Dieses Produkt wird mit Schließblech 16-7-4205 verwendet.

A	B	Kraft	Artikel-Nr.	Material	Dekor	Gewicht
45	17	3 kg	16-7-4204	Plastik	weiß	9g

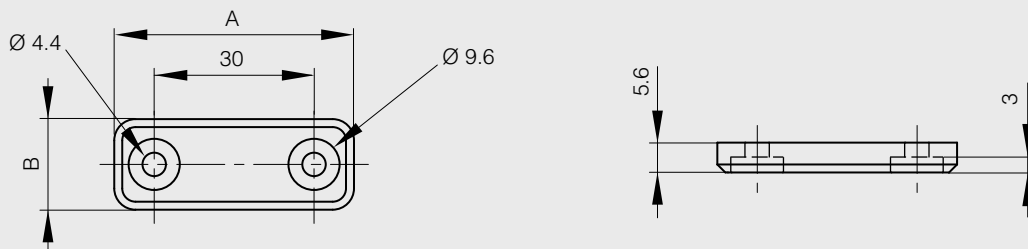

Schließblech für Kompakt-Magnetriegel 16-7-4204

neu!

Die nichtmagnetische Seite des Schließblechs ist blau gekennzeichnet. Dieses Schließblech hat dieselben Maße wie der entsprechende Riegel.

A	B	Artikel-Nr.	Material	Dekor	Gewicht
45	17	16-7-4205	Plastik	weiß	9g

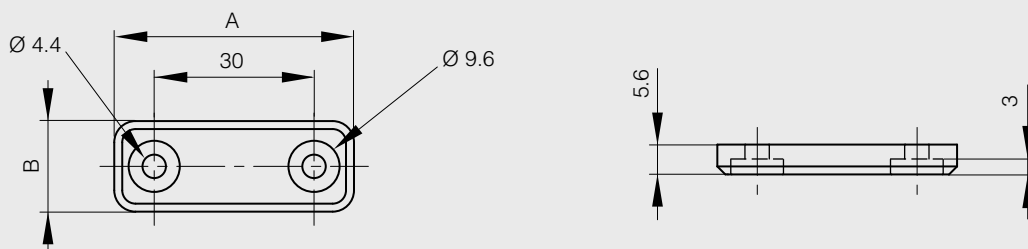

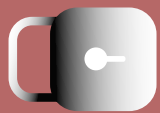

Dichter Magnetriegel

A	B	C	D	Kraft	Artikel-Nr.	Material	Dekor	Gewicht
50	21	13	40	3 kg	16-7-4081	Plastik	weiß	21g
50	21	13	40	3 kg	16-7-4206	Plastik	schwarz	21g

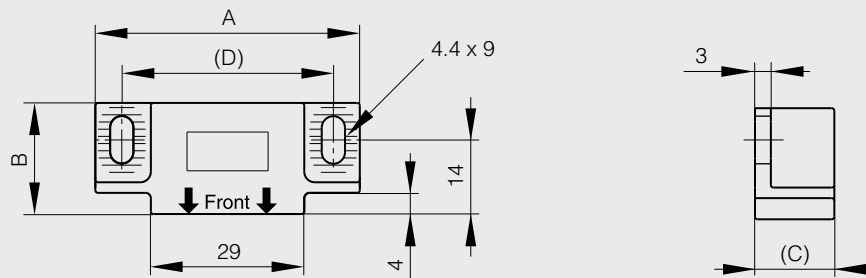

Schließblech für dichten Magnetriegel 16-7-4081 und 16-7-4206

A	B	C	D	Artikel-Nr.	Material	Dekor	Gewicht
49	15	2	40	16-7-4082	Edelstahl 1.4401	unbehandelt	10g

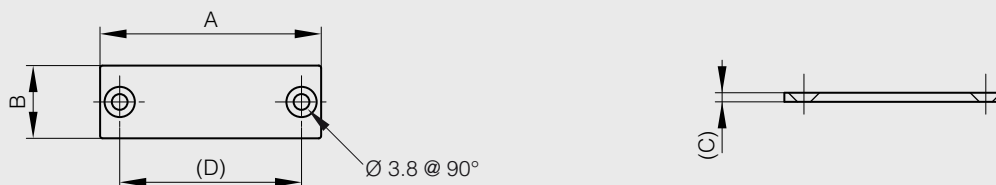

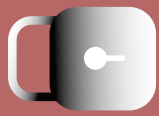

Ultraflacher Kompakt-Magnetriegel

Geeignet für Temperaturen unter 80°C.
Den Magnetteil vor Stoß schützen.
Die Schraubköpfe dürfen nicht überstehen.

A	B	Kraft	Artikel-Nr.	Material	Dekor	Gewicht
35	12	2.7 kg	16-7-4033	Stahl	vernickelt	4g

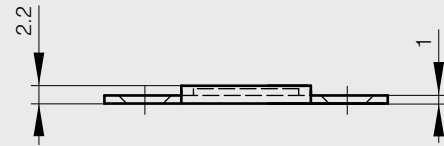
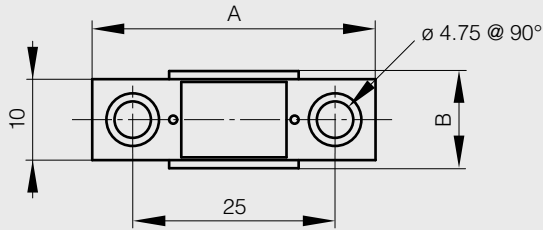

Kompakt-Magnetriegel

neu!

Geeignet für Temperaturen unter 80°C.
Den Magnetteil vor Stoß schützen.
Die Schraubköpfe dürfen nicht überstehen.

A	B	Kraft	Artikel-Nr.	Material	Dekor	Gewicht
41	16.5	4 kg	16-7-4207	Stahl	vernickelt	12g

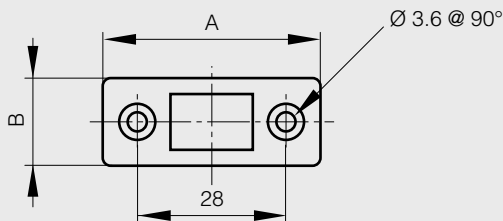

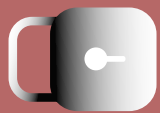

Verschraubbare Magnetriegel ohne Schließblech

A	B	C	D	Kraft	Artikel-Nr.	Material	Dekor	Gewicht
48.5	16.5	13	39	4 kg	16-7-3372	Plastik	weiß	18g
53.5	16.5	13.5	39	4 kg	16-7-3388	Plastik	weiß	24g

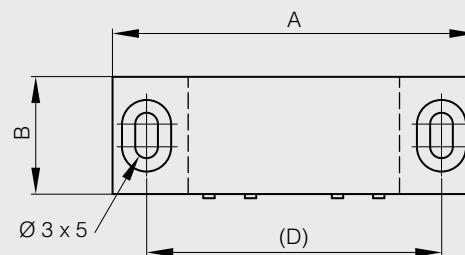
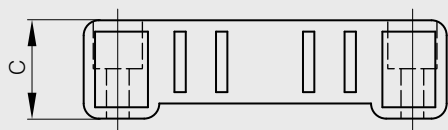

Schließbleche für Riegel 16-7-3372 und 16-7-3388

A	B	C	D	Ausführung	Artikel-Nr.	Material	Dekor	Gewicht
50.5	14	4.5	40	für Artikelnr.16-7-3372	16-7-3648	Plastik	weiß	6g
58	15	4.5	48	für Artikelnr. 16-7-3388	16-7-3649	Plastik	weiß	7.5g

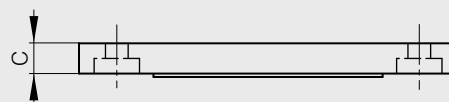
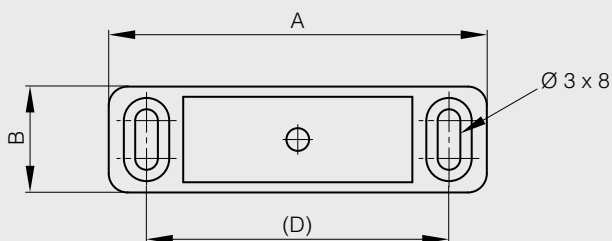



Verschraubbarer Magnetriegel mit Schließblech

A	B	C	Kraft	Artikel-Nr.	Material	Dekor	Gewicht
39.8	13.7	11.7	2 bis 3 kg	16-7-3492	Plastik	weiß	16.5g

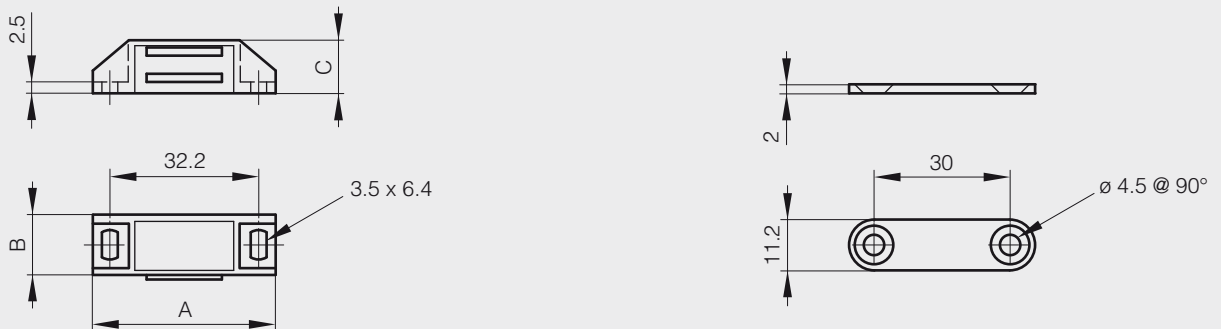

Verschraubbarer Magnetriegel ohne Schließblech

A	B	C	D	Kraft	Artikel-Nr.	Material	Dekor	Gewicht
48	15	19.2	38	4 kg	16-7-3390	Plastik	weiß	13g

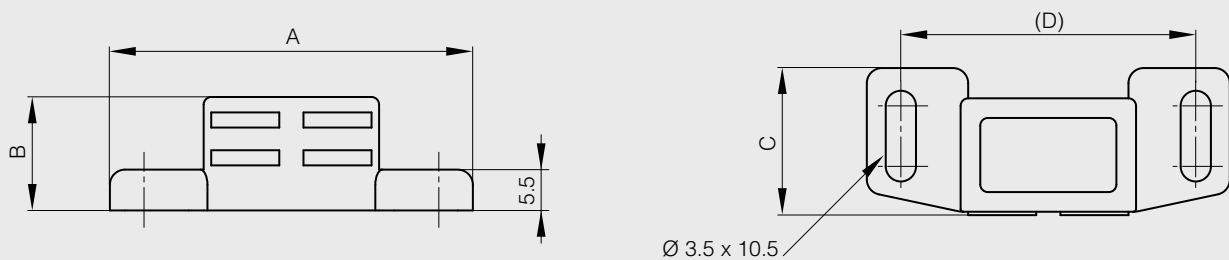



Schließblech für Riegel 16-7-3390

A	B	C	D	Artikel-Nr.	Material	Dekor	Gewicht
41	14	1.5	31	16-7-3351	Stahl	verzinkt	6g

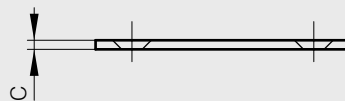
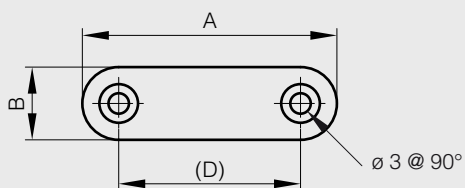

Verschraubbare Magnetriegel mit Schließblech

A	B	C	Kraft	Ausführung	Artikel-Nr.	Material	Dekor	Gewicht
49.4	16.4	15.6	4 kg	temperaturbeständig bis 80°C	16-7-3494	Zamak	vernickelt	56g
49.4	16.4	15.6	4 kg	temperaturbeständig bis 300°C	16-7-3610	Zamak	vernickelt	56g

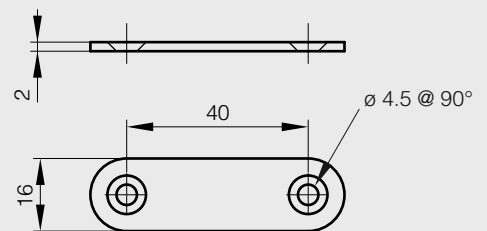
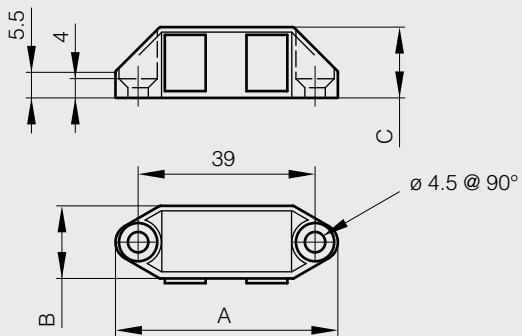

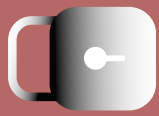

Verschraubbarer Magnetriegel mit Schließblech

A	B	C	Kraft	Artikel-Nr.	Material	Dekor	Gewicht
54	16	15	4 kg	16-7-3483	Zamak	vernickelt	49g

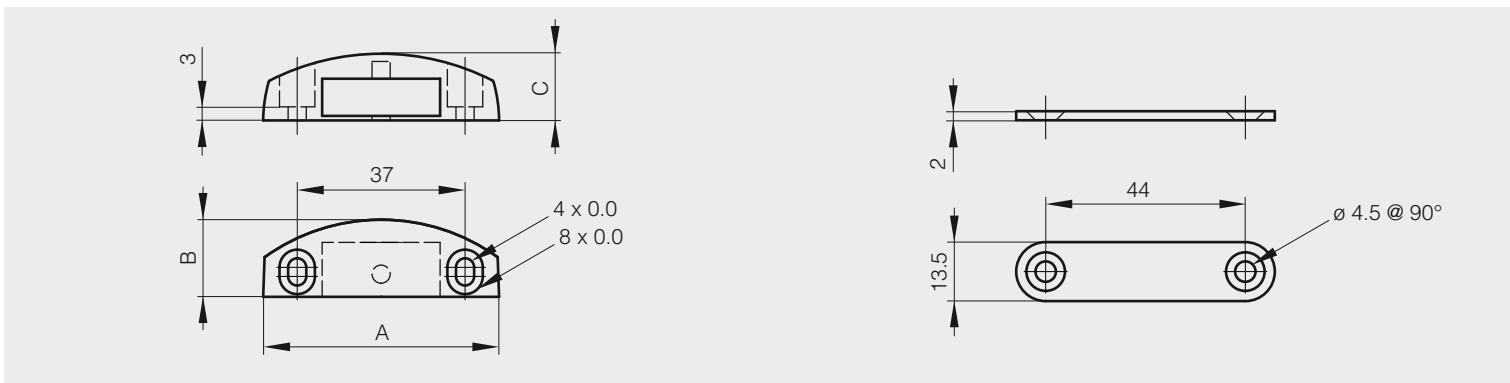

Magnet aus Edelstahl 1.4016

A	B	C	D	E	F	G	H	Kraft	Artikel-Nr.	Material	Dekor	Gewicht
86	13	15	77	12	57	70	9.2	4.8 kg	16-7-3861	Plastik	weiß	100g
105.3	16	18	94	14	65	79	11.4	5.6 kg	16-7-3862	Plastik	weiß	100g

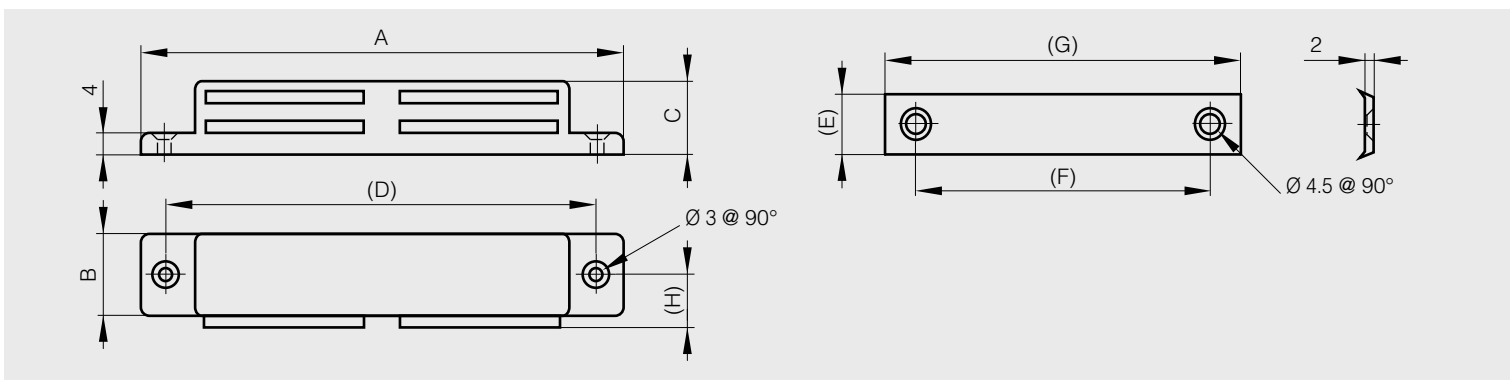

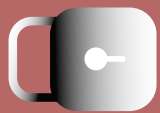

Verschraubbarer Magnetriegel mit Schließblech

Die angegebene Kraft wird nur über das entsprechende Schließblech erreicht.

A	B	C	C1	C2	D	E	F	G	S1	S2	Kraft	Artikel-Nr.	Material	Dekor	Gewicht
56	12	15.2	5	5	40	15.5	57	42	3.2x5	7	3 kg	16-7-3486	Plastik	weiß	23.5g
58	12	15.2	5	5	42	15.5	57	42	3.2x6	8.1	4 kg	16-7-3487	Plastik	weiß	31g
62.1	12.6	15.2	6	5.5	45	16.4	62	44.7	3.2x6	8.1	6 kg	16-7-3488	Plastik	weiß	41g

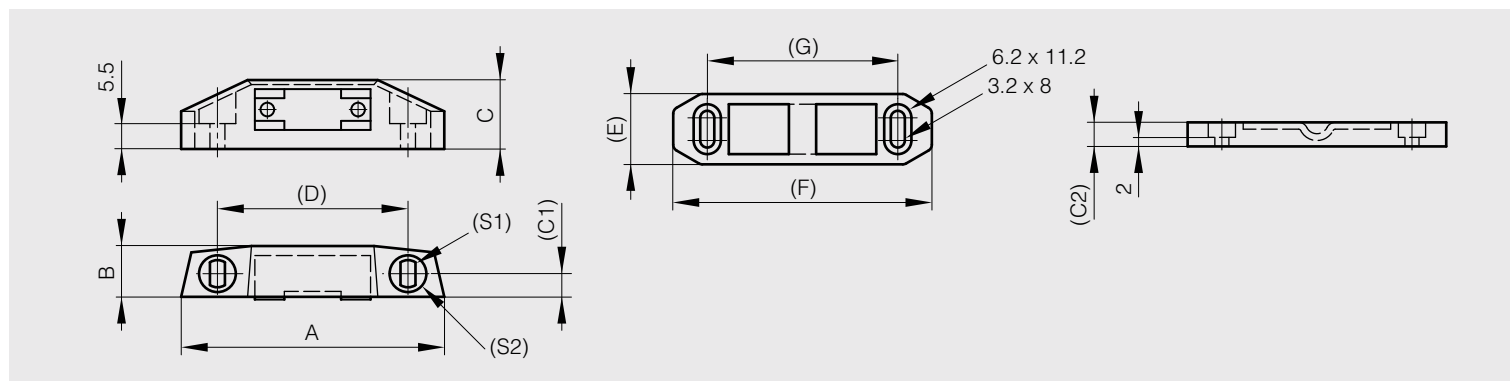

Verschraubbarer Magnetriegel mit Schließblech

A	B	C	Kraft	Ausführung	Artikel-Nr.	Material	Dekor	Gewicht
86	16.4	15.6	8 kg	temperaturbeständig bis 80°C	16-7-3391	Zamak	vernickelt	112g
86	16.4	15.6	8 kg	temperaturbeständig bis 300°C	16-7-3611	Zamak	vernickelt	112g

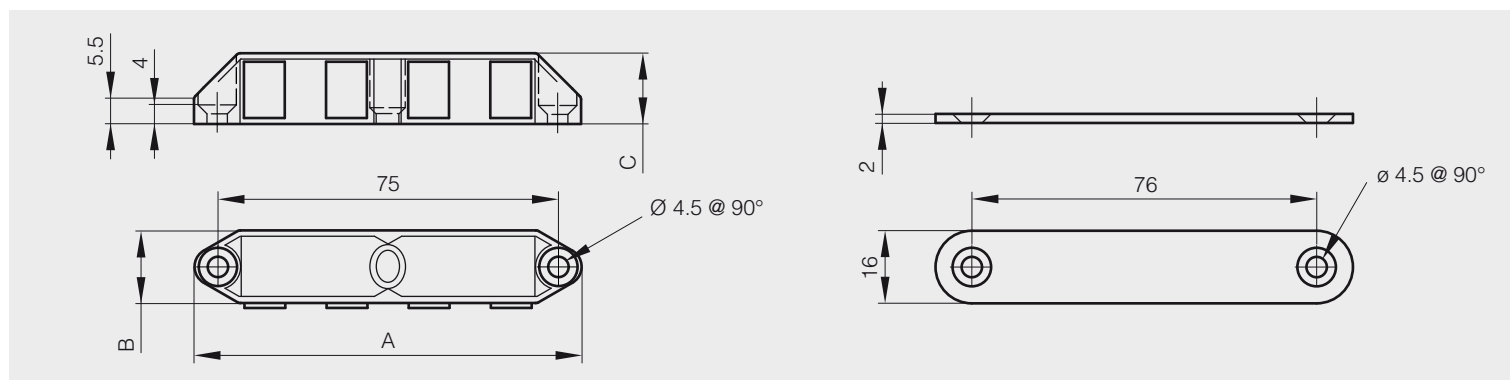



Verschraubbarer Magnetriegel ohne Schließblech

A	B	C	D	Kraft	Artikel-Nr.	Material	Dekor	Gewicht
74	14	17.5	64	12 kg	16-7-3672	Plastik	weiß	37g

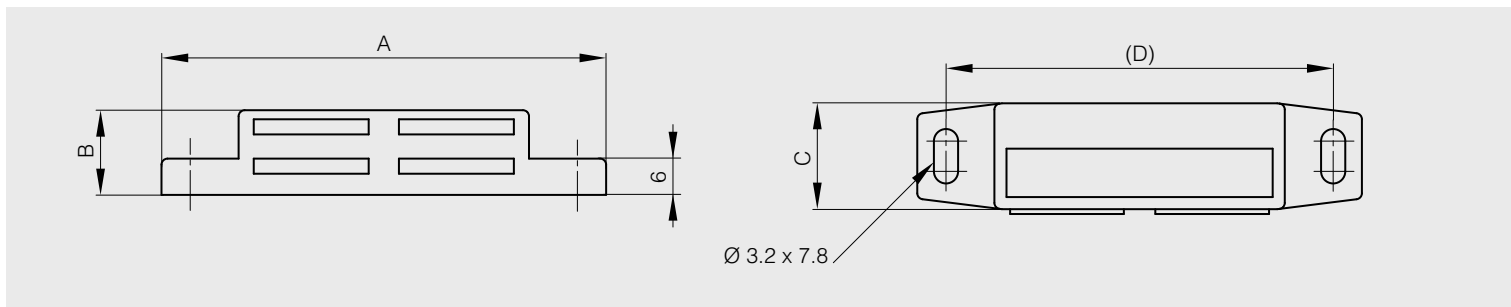

Schließblech für Riegel 16-7-3672

A	B	C	D	Artikel-Nr.	Material	Dekor	Gewicht
66	12	2	54	16-7-3673	Stahl	verzinkt	11g

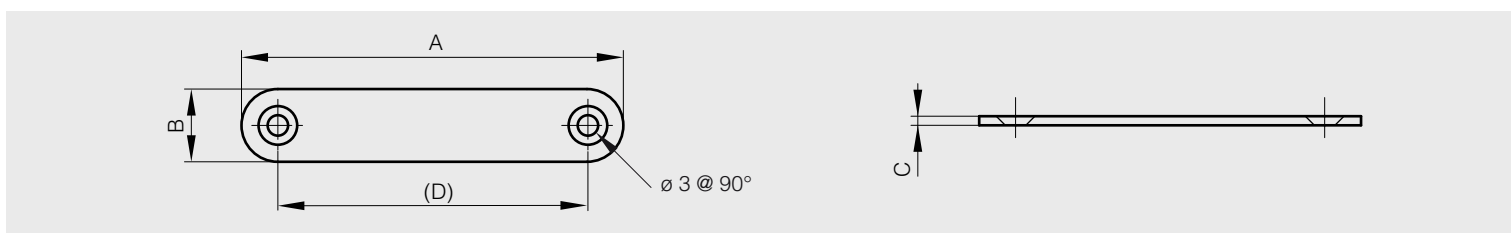

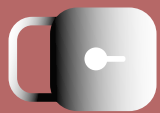

Einrastriegel

neu!

Klemmriegel für Blattstärken 1,6 mm oder 2,6 mm.
Flexible Befestigungsteile als Einbauhilfe.
Die Einbauöffnungen variieren je nach Blechstärke (Zeichnung).

A	B	C	Kraft	Artikel-Nr.	Material	Dekor	Gewicht
41	13	14.6	1.2 kg	16-7-4208	Plastik	schwarz	5g
41	13	14.6	3 kg	16-7-4209	Plastik	schwarz	5.5g

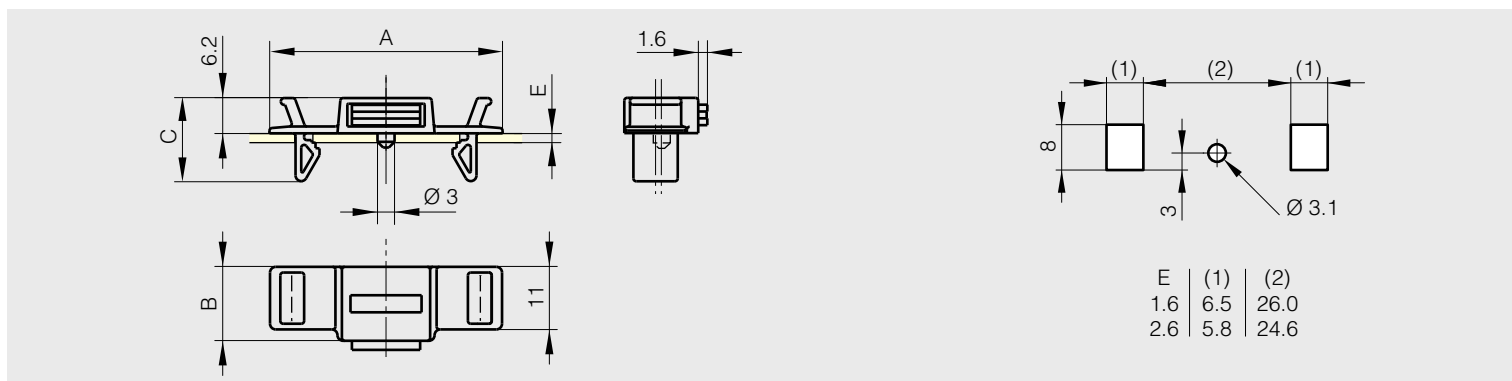

A	B	C	D	E	Kraft	Ausführung	Artikel-Nr.	Material	Dekor	Gewicht
25.5	12.3	10.4	23	11	1.5 kg	für eine Blechdicke von 1,5	16-7-4013	Polypropylen	weiß	4g
25.5	9.6	11	23	8.2	1.8 kg	für eine Blechdicke von 1,5	16-7-4014	Polypropylen	weiß	4g
39.5	10	11	35	8.2	4 kg	für eine Blechdicke von 1,5	16-7-4015	Polypropylen	weiß	8g
54	12.5	14.5	51.5	10.8	15 kg	für eine Blechdicke von 2,0	16-7-3674	Polypropylen	schwarz	32g

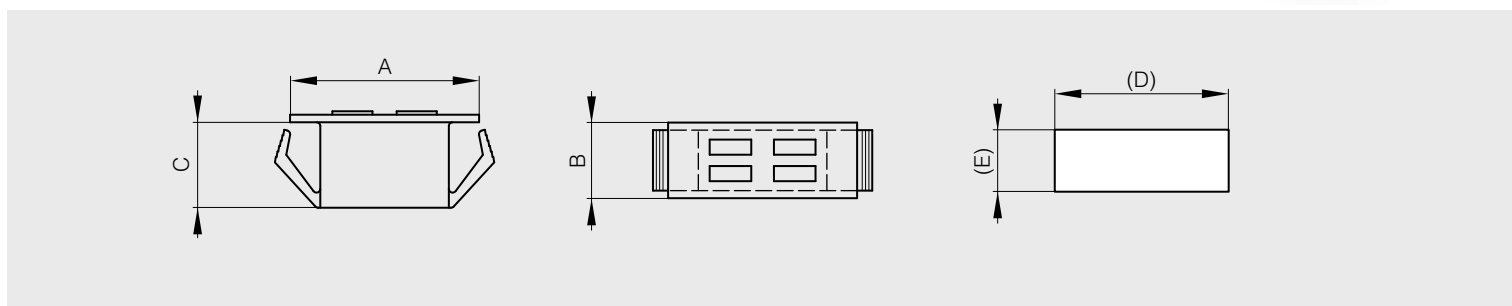



Schließbleche für Einrast-Magnetriegel

A	B	C	D	Ausführung	Artikel-Nr.	Material	Dekor	Gewicht
41	14	1.5	31	für Artikelnr. 16-7-4013 und 16-7-4014	16-7-3351	Stahl	verzinkt	6g
66	12	2	54	für Artikelnr. 16-7-3674 und 16-7-4015	16-7-3673	Stahl	verzinkt	11g

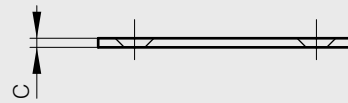
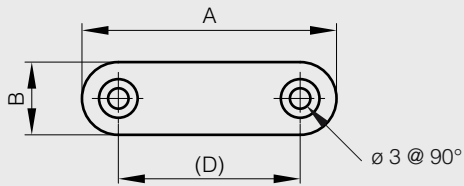

Gehäuse

Gehäuse für Art.-Nr. 16-7-3674

A	B	C	D	Artikel-Nr.	Material	Dekor	Gewicht
75.5	14.8	18.5	65	16-7-3675	Plastik	schwarz	8g

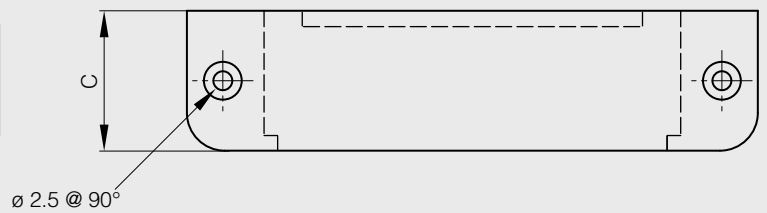
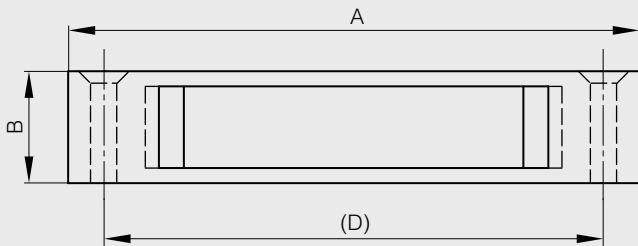

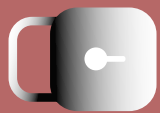

Versenkbarer Magnetriegel mit Schließblech

A	B	C	D	Kraft	Ausführung	Artikel-Nr.	Material	Dekor	Gewicht
56	16.3	16.7	42	4 kg	temperaturbeständig bis 150°C	16-7-3484	Zamak	vernickelt	63.5g

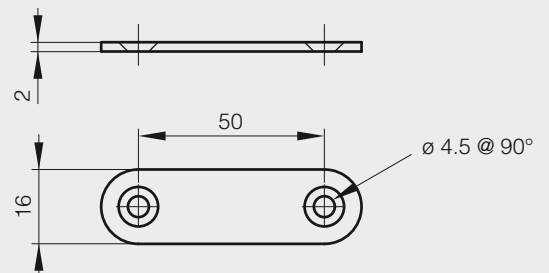
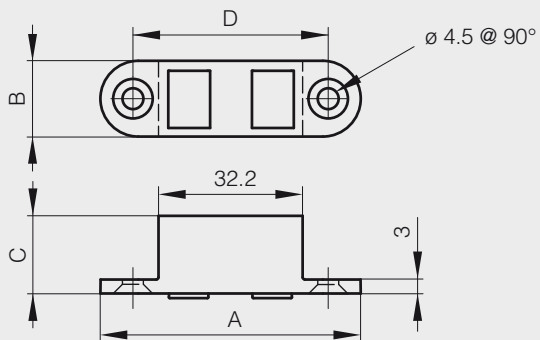

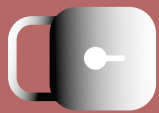

Versenkbarer Kompakt-Magnetriegel ohne Schließblech

A	B	D	Kraft	Artikel-Nr.	Material	Dekor	Gewicht
24	15	13.5	5 kg	16-7-3387	Stahl	verzinkt	13g



A	B	D	Kraft	Artikel-Nr.	Material	Dekor	Gewicht
24	12	13.5	4.2 kg	16-7-3378	Stahl	schwarz	14g



Versenkbarer Kompakt-Magnetriegel ohne Schließblech

Hitzebeständig bis zu 250°C.

A	B	D	Kraft	Artikel-Nr.	Material	Dekor	Gewicht
26	12	13.5	4.2 kg	16-7-3490	Stahl	verzinkt	17.5g
29	16	17.5	8 kg	16-7-3651	Stahl	verzinkt	40g

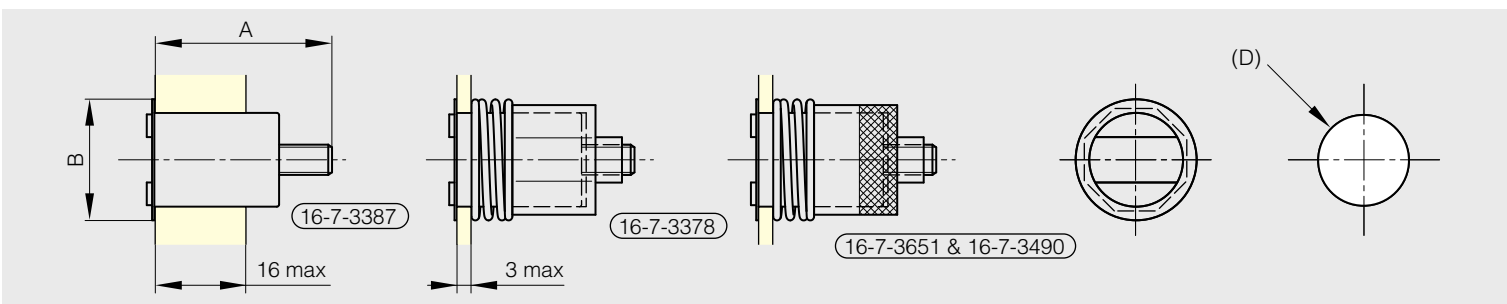

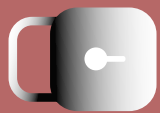

Schließblech für Riegel 16-7-3378, 16-7-3387, 16-7-3490 und 16-7-3651

A	B	Artikel-Nr.	Material	Dekor	Gewicht
15.1	3	16-7-3349	Stahl	verzinkt	4g

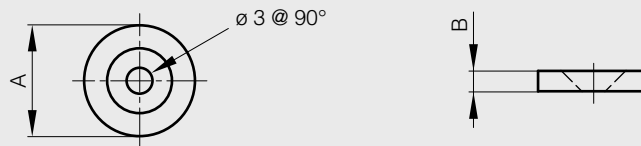

Versenkbarer Magnetriegel ohne Schließblech

A	B	C	D	Kraft	Artikel-Nr.	Material	Dekor	Gewicht
53	14.2	15.5	44	7 kg	16-7-3373	Plastik	weiß	26g

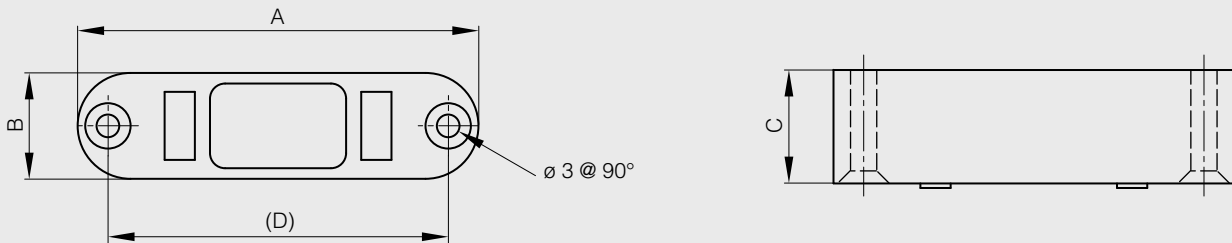

Schließblech für Riegel 16-7-3373

A	B	C	D	Artikel-Nr.	Material	Dekor	Gewicht
53.5	15	6.5	43.5	16-7-3352	Plastik	weiß	13g

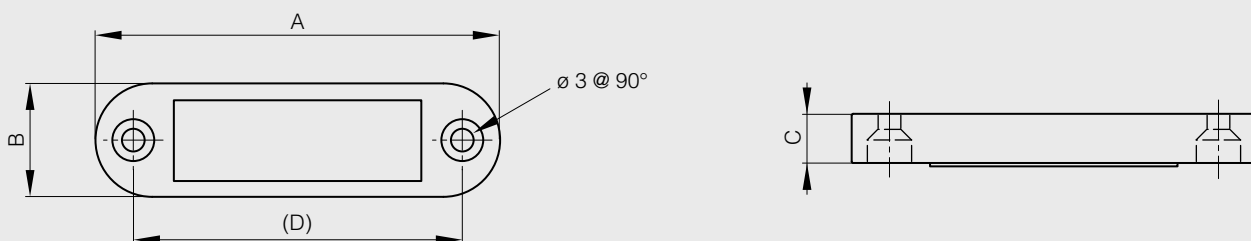

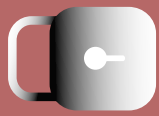

Selbstklebende Magnetprofile

Rollen mit 30 m.

Hitzebeständigkeit: 100°C.

B	C	Kraft	Artikel-Nr.	Material	Dekor	Gewicht
19	1.5	55 g/cm ²	16-7-3682	flexibler Magnet	verklebt	3300g

