

# CLIP'N TURN

## Clip-on quarter-turn

**CLIP'N TURN quarter-turns is a range of cost effective latching systems. The CLIP'N TURN is a clip-on quarter-turn easy to mount .**

- Clip-on
- Made of 2 components only
- Tool-less assembly
- Easy to mount
- Quick to mount (less than 5 seconds)
- Cost effective
- Rotation up to 90°
- Assembly indication on the product (arrows)
- Disassembly is not possible
- The specific cut-out has two functions (stop and assembly fool-proofing device : 1 only position possible)
- For lightweight door applications
- 2 actuators : slotted 2x4 and wing
- 3 cam heights : 13.5, 18 or 25 mm
- Colour : black
- Temperature range : -20/+60°C
- Sheet thickness : up to 4 mm for products with cam height 13.5 or 18 mm and up to 6 mm for products with cam height 25 mm.
- Clip delivered with housing
- Patented

### Application examples :

- Sheet metal fabricators
- Enclosures and 19" racks
- Industrial furniture
- Sanitary equipments
- HVAC
- Lifts
- Recreational vehicles / Ship building
- Etc...

### Material :

- Housing in POM
- Clip in PA-6.6

### Strength guideline :

- Tensile pull-out force (extraction) : 600 N



Wing head CLIP'N TURN

Wing head products with clip :

- Cam height 13.5 mm : **16-1-8001**
- Cam height 18 mm : **16-1-8003**
- Cam height 25 mm : **16-1-8005**



Slotted 2x4 head CLIP'N TURN

Slotted 2x4 products with clip :

- Cam height 13.5 mm : **16-1-8002**
- Cam height 18 mm : **16-1-8004**
- Cam height 25 mm : **16-1-8006**

## CLIP'N TURN Clip-on quarter-turn

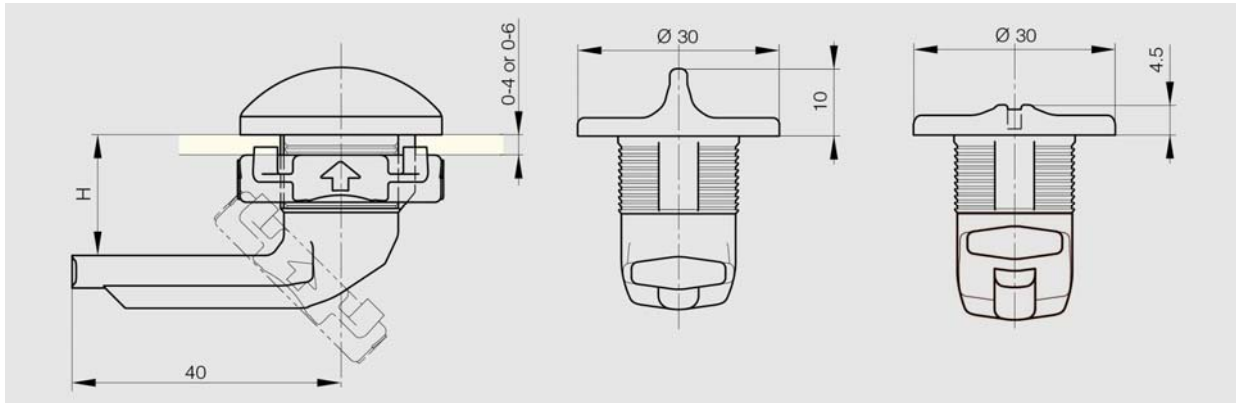

CLIP'N TURN quarter-turn mounting and dimension

### Cut-out characteristics :

- Cut-out diameter :  $18.3^{\pm 0.2}$  mm
- Notch diameter :  $22.2^{\pm 0.2}$  mm
- Notch angle :  $128^{\circ}$

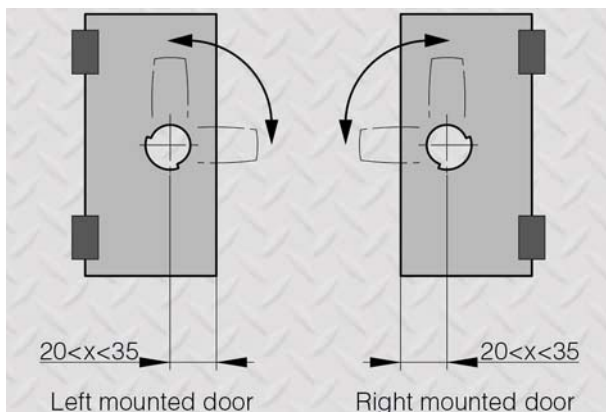

Cut-out position for CLIP'N TURN quarter-turn

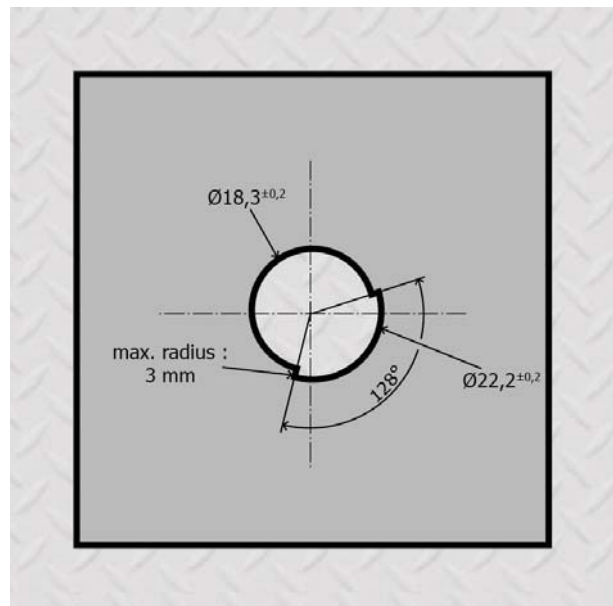

Cut-out shape and dimension for CLIP'N TURN quarter-turn

**Pinet Industrie** • 9, rue de l'Etang • Parc international d'activités Paris Nord 2  
 BP 62036 • 95971 Roissy Charles de Gaulle Cedex • France  
 Tél. : 33 (0)1 49 38 27 00 • Fax : 33 (0)1 48 63 77 70 • [www.pinet.tm.fr](http://www.pinet.tm.fr)

SAS au capital de 4 118 400 € • RCS Bobigny et SIRET • B 407 485 556 00010 • Code NAF : 286 F