

Aluminium profile spring hinges

The family of aluminium profile spring hinges combines a attractively-designed range of products with high performance characteristics.

Main features :

- Automatic opening and closing of a door
- A completely invisible spring mechanism
- Different spring torques available
- Corrosion-resistant
- No play in the hinge
- Elegant design
- Anodised clear or anodised black finish
- Hinges with the same design and footprint, but other functional characteristics (friction & detent) available for a smart combination.

Application examples :

- Doors or panels articulation
- Machine tools
- Metal furniture
- Medical equipment
- Etc.

Material :

Aluminium, black or clear anodised
Plug in PA-6,6
Washer in POM
Spring in steel

References :

- **Spring force 0,35 N.m**
72-1-4220, clear anodised
72-1-4221, black anodised
- **Spring force 0,70 N.m**
72-1-4218, clear anodised
72-1-4219, black anodised
- **Spring force 1,3 N.m**
72-1-4222, clear anodised
72-1-4223, black anodised



Clear anodised aluminium profile spring hinge
(available in 0,35 N.m, 0,70 N.m and 1,3 N.m)



Black anodised aluminium profile spring hinge
(available in 0,35 N.m, 0,70 N.m and 1,3 N.m)

Aluminium profile spring hinges

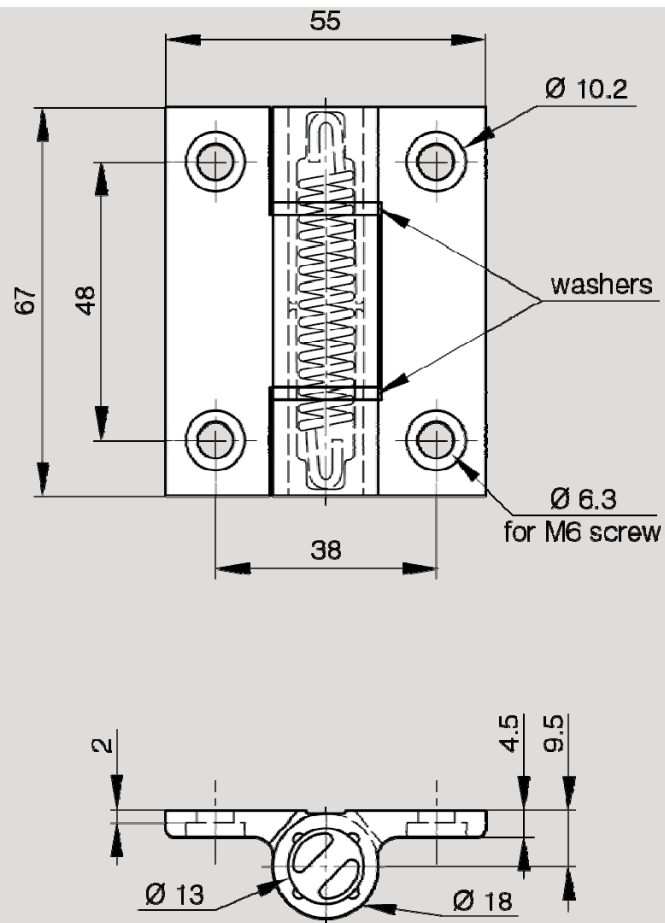

Other information :

Total swing : 180°

Recommended temperature range : -20°C +80°C

Fixing screws : according to DIN 912

Spring forces :

- Aluminium profile spring hinges 0,35 N.m :
M(0°) : 0,35 N.m / M(90°) : 0,24 N.m / M(180°) : 0,12 N.m
- Aluminium profile spring hinges 0,70 N.m :
M(0°) : 0,70 N.m / M(90°) : 0,45 N.m / M(180°) : 0,23 N.m
- Aluminium profile spring hinges 1,3 N.m :
M(0°) : 1,30 N.m / M(90°) : 1,10 N.m / M(180°) : 0,90 N.m

Performance :

Aluminium profile spring hinges 0,35 and 0,70 N.m are guaranteed over 30,000 cycles.

Aluminium profile spring hinges 1,3 N.m are guaranteed over 10,000 cycles.

Subject to technical changes

Pinet Industrie • 9, rue de l'Étang • Parc international d'activités Paris Nord 2
BP 62036 • 95971 Roissy Charles de Gaulle Cedex • France
Tél. : 33 (0)1 49 38 27 00 • Fax : 33 (0)1 48 63 77 70 • www.pinet.tm.fr

SAS au capital de 4 118 400 € • RCS Bobigny et SIRET • B 407 485 556 00010 • Code NAF : 286 F